

22.94 [582.80mm]

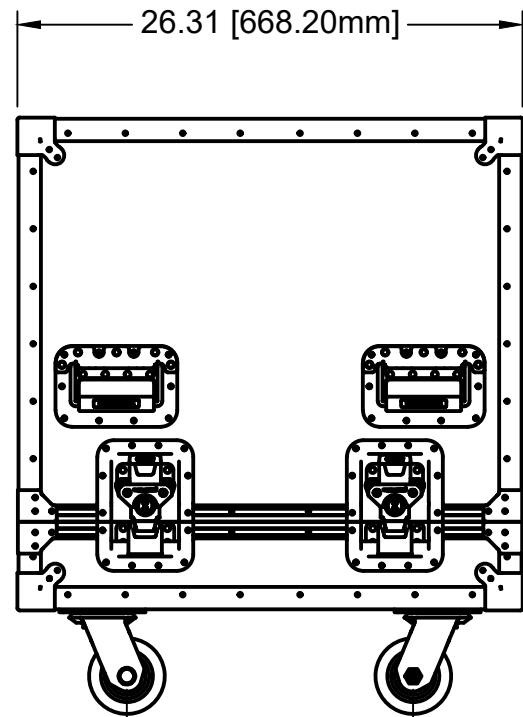

26.31 [668.20mm]

14.91 [378.60mm]

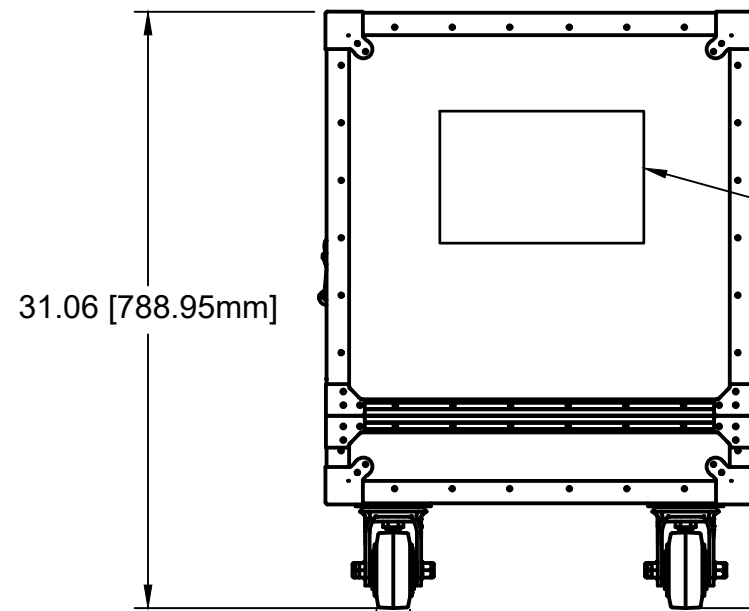

31.06 [788.95mm]

16.15 [410.32mm]

1.75 [44.45mm]

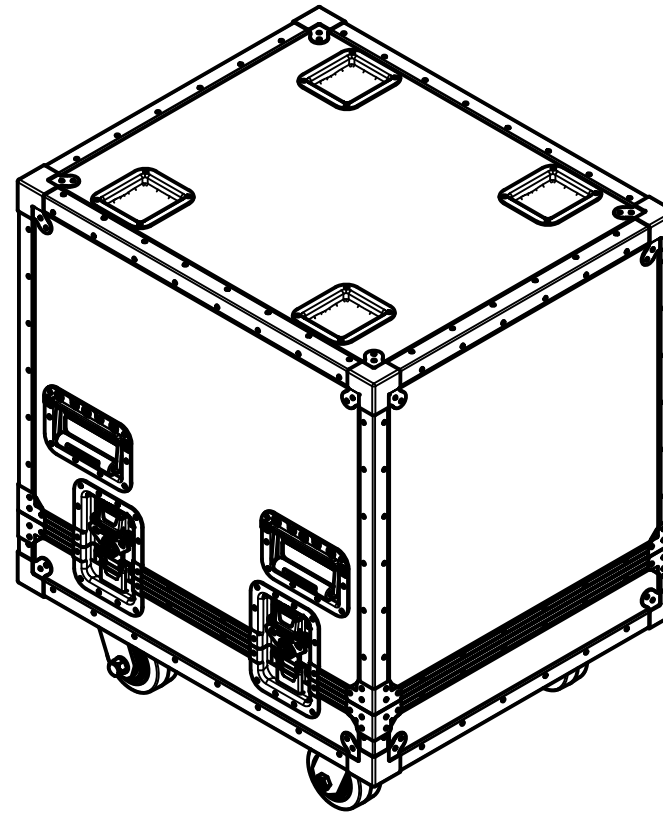

RECESSED LABEL DISH

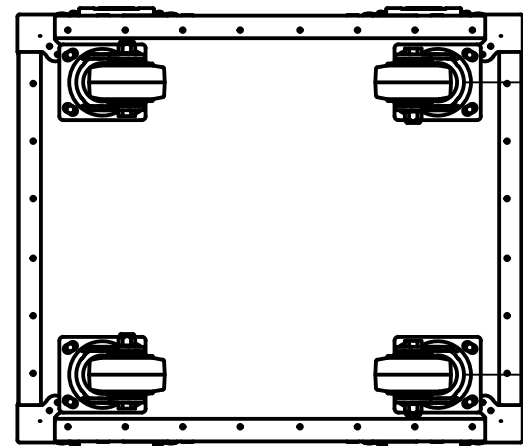
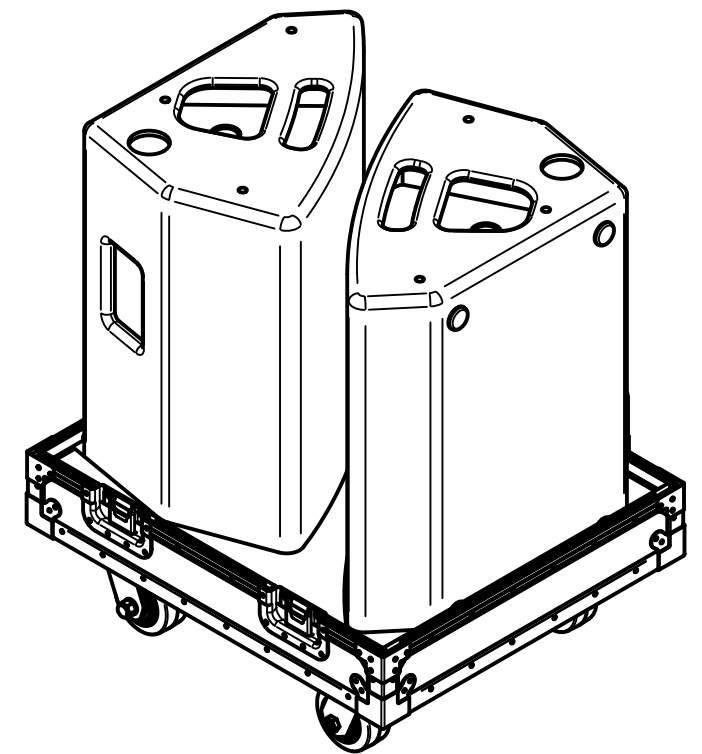

15.22 [386.68mm]

Exterior 12 MM Phenolic HEXA GRIP SURFACE (European Origin)  
 Cabinet Protection Polyethylene Foam  
 Zinc Plated Steel Corners,  
 Bright Aluminum Extrusion

DETAILS:

DIMENSIONS ARE IN INCHES  
 TOLERANCES:  
 LINEAR ± 0.05  
 MACH ANGULAR ± 0.5°  
 BEND ANGULAR ± 1.0°

THE INFORMATION CONTAINED IN THIS DOCUMENT IS THE SOLE PROPERTY OF **RMS-ACOUSTICS**. ANY COPY OR REPRODUCTION OF THIS DOCUMENT IN PART OR AS A WHOLE FOR THE BASIS OF MANUFACTURE OR SALE OF ANY ITEM OR APPARATUS DESCRIBED HEREIN WITHOUT WRITTEN AUTHORIZATION FROM **RMS-ACOUSTICS** IS PROHIBITED.  
**DO NOT SCALE DRAWING**

**RMS**  
 ACOUSTICS

WWW.RMS-ACOUSTICS.COM  
 13720 24TH ST E  
 UNIT E110  
 SUMNER, WA 98390

APPROVALS	DATE	PROJECT	SIZE	REV
DRAWN: Ryan McCauley	1/17/2023	M15X ROAD CASE 2 PACK	B	A
CHECKED:		1/1 SCALE 1:10	1/17/2023	