

TOP

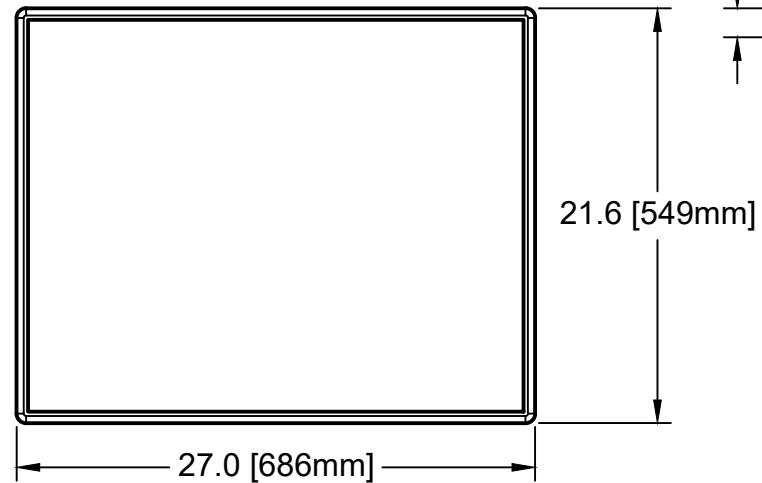

FRONT

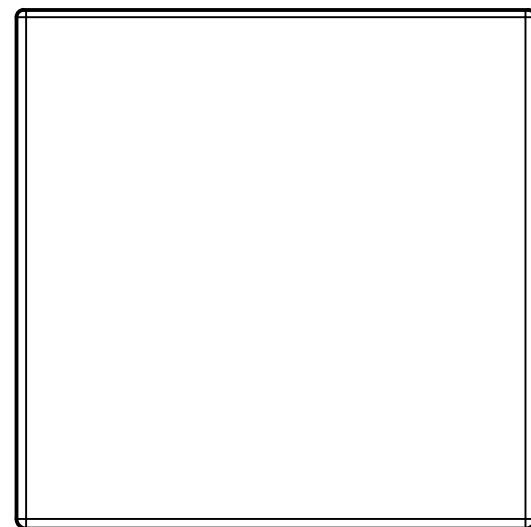

BOTTOM

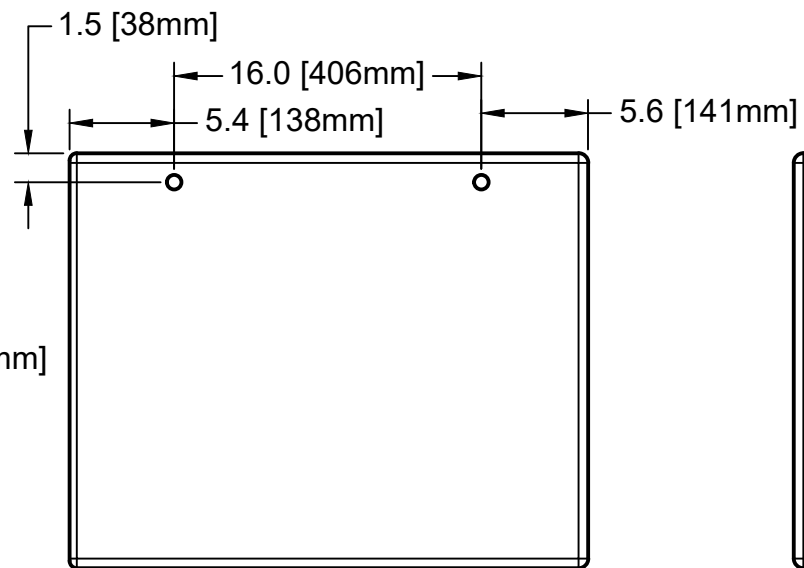

SIDE

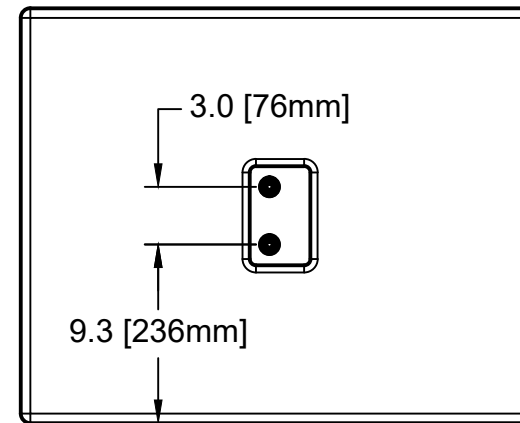

REAR

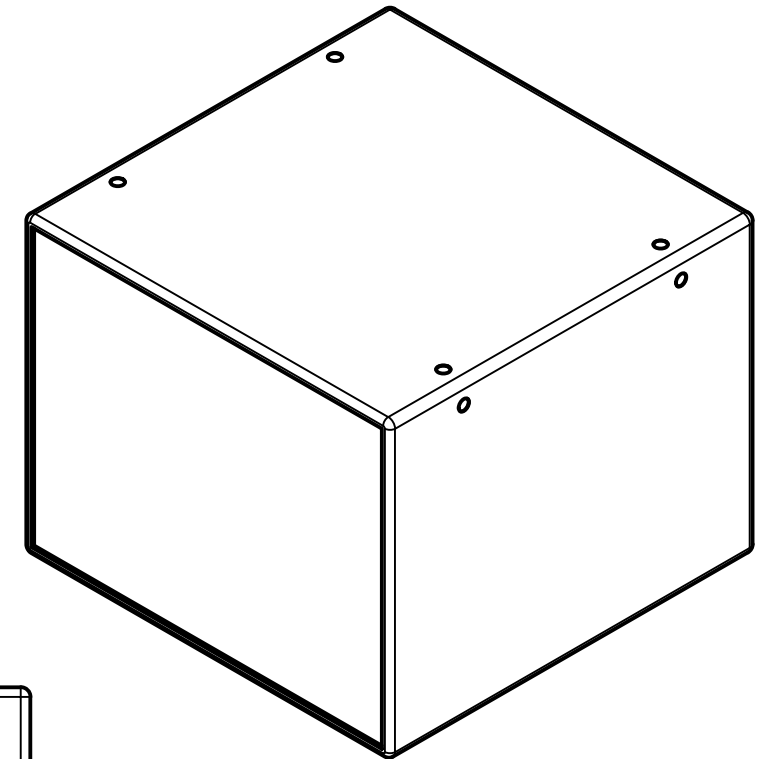

M10 Eye Bolts with internal Steel L Bracket Top and Sides

Electrical Connectivity via NL4 pins 1+1- pins 2 NA

Weight 105 Lbs 47.7 Kg

Ordering Options:

-W White (Upcharge)

-C Custom Color - Must provide RAL, Pantone, or Sherwin Williams # (Upcharge)

-X1 Moderate Weatherization -- Only certain colors possible (Upcharge)

DETAILS:

DIMENSIONS ARE IN INCHES  
TOLERANCES:  
LINEAR ± 0.05  
MACH ANGULAR ± 0.5°  
BEND ANGULAR ± 1°

THE INFORMATION CONTAINED IN THIS DOCUMENT IS THE SOLE PROPERTY OF **RMS-ACOUSTICS**. ANY COPY OR REPRODUCTION OF THIS DOCUMENT IN PART OR AS A WHOLE FOR THE BASIS OF MANUFACTURE OR SALE OF ANY ITEM OR APPARATUS DESCRIBED HEREIN WITHOUT WRITTEN AUTHORIZATION FROM **RMS-ACOUSTICS** IS PROHIBITED.  
**DO NOT SCALE DRAWING**

**RMS**  
ACOUSTICS

WWW.RMS-ACOUSTICS.COM  
13720 24TH ST E  
UNIT E110  
SUMNER, WA 98390

APPROVALS	DATE	PROJECT	SIZE	REV
DRAWN: Ryan McCauley	4/23/2024	M118i Eye Bolts Dimensional Drawing	B	A
CHECKED:		1/1 SCALE 1:10	4/23/2024	