

REVISION HISTORY			
REV	DESCRIPTION	DATE	APPROVED
A	HARDWARE TRANSITIONED TO METRIC	3/28/2024	RM

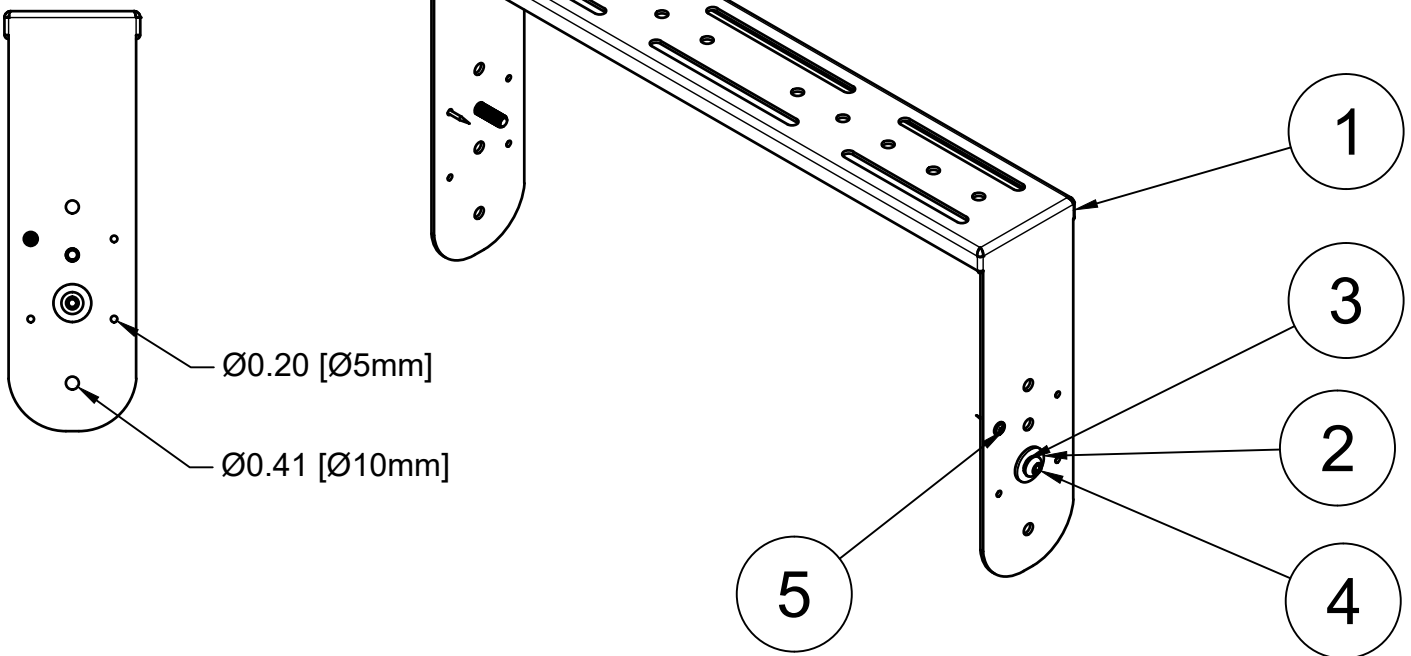
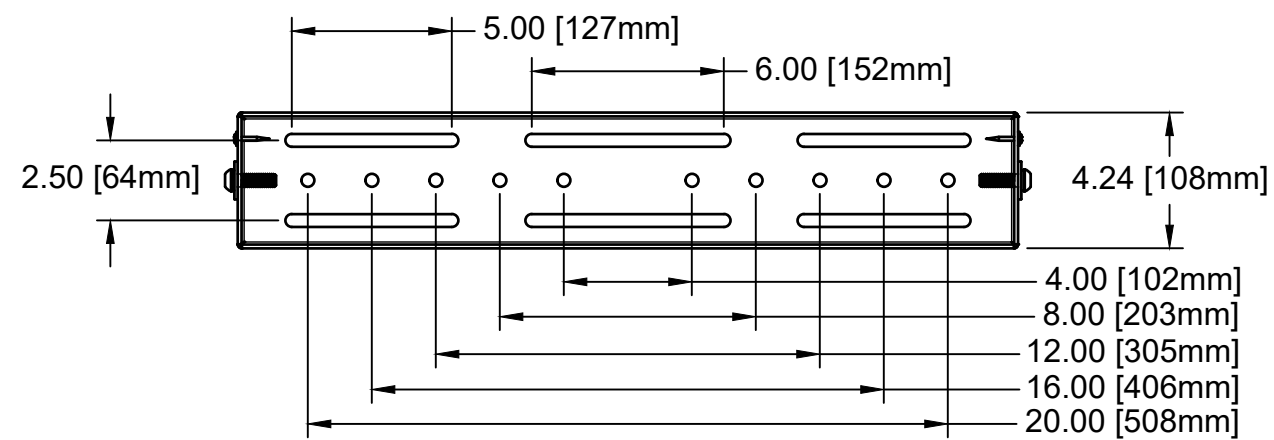
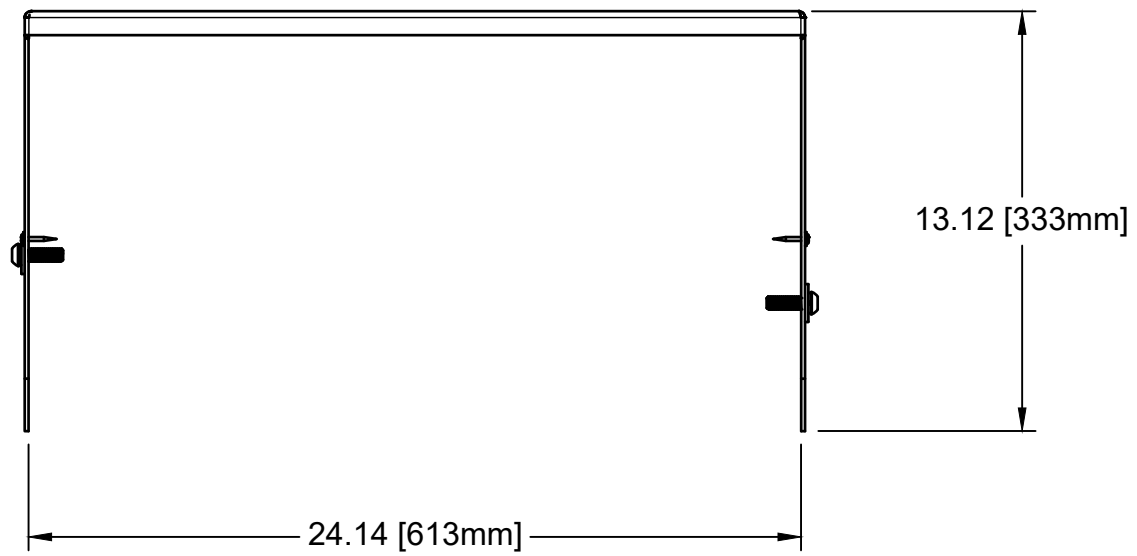

PARTS LIST		
ITEM	QTY	PART NUMBER
1	1	C12HU R2
2	2	M10 FW SS BO 30MM OD
3	2	M10 LW SS BO
4	2	M10 BTN HD SS BO 35MM
5	2	8-0100 WASHER HEAD COMBI DRIVE BPHS

Ordering Options  
 -BK for Black  
 -W for White  
 -C with Pantone or RAL # for Custom Color (Upcharge)  
 -X1 for moderate weatherize, Standard is grey or White, Not all colors compatible (Upcharge)  
 -X2 for extreme weatherize, Standard is grey or White, Not all colors compatible (Upcharge)

DETAILS:  
 Black Powder Coat  
 Cardinal T001-BK120  
 Optional White PC  
 11 Gauge Cold Rolled Steel  
 DIMENSIONS ARE IN INCHES  
 TOLERANCES:  
 LINEAR ± 0.05  
 MACH ANGULAR ± 0.5°  
 BEND ANGULAR ± 1°

THE INFORMATION CONTAINED IN THIS DOCUMENT IS THE SOLE PROPERTY OF **RMS-ACOUSTICS**. ANY COPY OR REPRODUCTION OF THIS DOCUMENT IN PART OR AS A WHOLE FOR THE BASIS OF MANUFACTURE OR SALE OF ANY ITEM OR APPARATUS DESCRIBED HEREIN WITHOUT WRITTEN AUTHORIZATION FROM **RMS-ACOUSTICS** IS PROHIBITED.  
**DO NOT SCALE DRAWING**

**RMS**  
 ACOUSTICS  
 WWW.RMS-ACOUSTICS.COM  
 13720 24TH ST E  
 UNIT E110  
 SUMNER, WA 98390

APPROVALS	DATE	PROJECT	SIZE	REV
DRAWN: Ryan McCauley CHECKED:	3/29/2024	C12HU R2 Drawing	B	A
		1/1 SCALE 1:6		3/29/2024